

J4 VIBRATING WIRE PERIMETRIC JOINTMETER

Datasheet J4

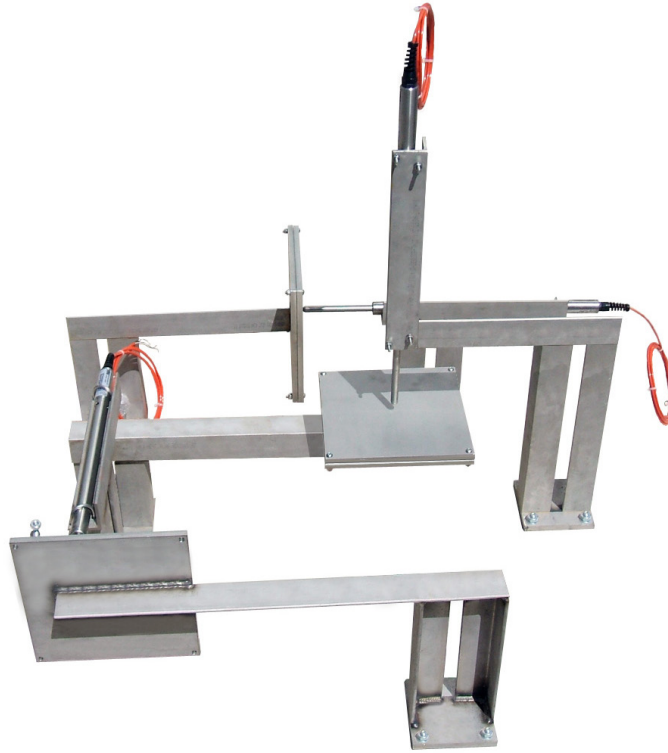

Description

The Vibrating Wire Perimetric Jointmeter is designed to monitor three way displacement at joints and cracks. The reference anvil design allows the Vibrating Wire transducers to show independent movement in all directions, irrespective of each other.

The Jointmeter comprises a 3D mounting system which consists of Stainless Steel arms with fixing anchors. Three Vibrating Wire displacement transducers, which also monitor temperature, are installed within the mounting system and positioned for monitoring.

Data is retrieved either remotely or manually; a datalogger is used for remote monitoring and a readout unit for manual reading.

The Vibrating Wire Perimetric Jointmeter is easy to install, requiring minor drilling into the concrete slab and is particularly suited for use on concrete faced dams.

Features

- Reads in X, Y and Z axes
- Uses proven Vibrating Wire technology
- Proven in long-term monitoring
- Suitable for manual or remote monitoring
- Fully waterproof
- Fitted with thermistor for temperature monitoring
- Accurate and robust

Benefits

- Three way independent movement monitoring in one easy installation
- Accurate, repeatable readings over long cable lengths
- Long working life, long-term stability and reliability
- Over-voltage surge arrestor fitted to protect against electrical damage
- Connecting cable is strong, screened and flexible



Comprehensive information about this product and our full range is available at soilinstruments.com
If you would like to speak with someone directly please call +44 (0)1825 765044 or email sales@soilinstruments.com

VIBRATING WIRE PRINCIPLE



A high carbon steel wire is held in tension between a fixed point and a movable point within the sensor.

The physical changes measured by the sensor result in small changes to the position of the movable point which results in a change to the tension of the wire.

The wire may be excited by either plucking or sweeping via a coil adjacent to the wire. The resulting resonant frequency (which is relative to the tension of the wire) is then recorded by the same coil. The reading can be displayed by instrument readout or recorded by data logging equipment.

Operation

The Stainless Steel arms of the jointmeter are installed either side of a joint or crack.

Once the arms are securely fixed in position, the VW transducers are positioned against the reference anvil faces, most commonly set to their mid-point. The transducer cables are then either wired into a datalogger for remote monitoring, or wired into a terminal or junction box to manually record the readings with a readout unit.

Movement in the monitored position will result in relative change between the arms; this in turn will cause one or more of the VW transducer rods to move independently, changing the frequency of the wire. This change in frequency is recorded and can be converted to show the movement in millimetres.

When the installation is complete an initial (datum) reading is taken and this can then be compared to all subsequent readings to give the change and magnitude of displacement.

Applications

Vibrating Wire Triaxial Jointmeters are used for monitoring of movements at construction joints.

Typical examples include:

- Concrete dams
- Tunnels
- Tanks
- Masonry structures

Associated products

For details on:

Catalogue code:

Terminal/Junction Boxes

RO-TB/JB/TJ

Dataloggers

D1

VWnote

RO-1- VVNOTE

View our full product range on www.soilinstruments.com

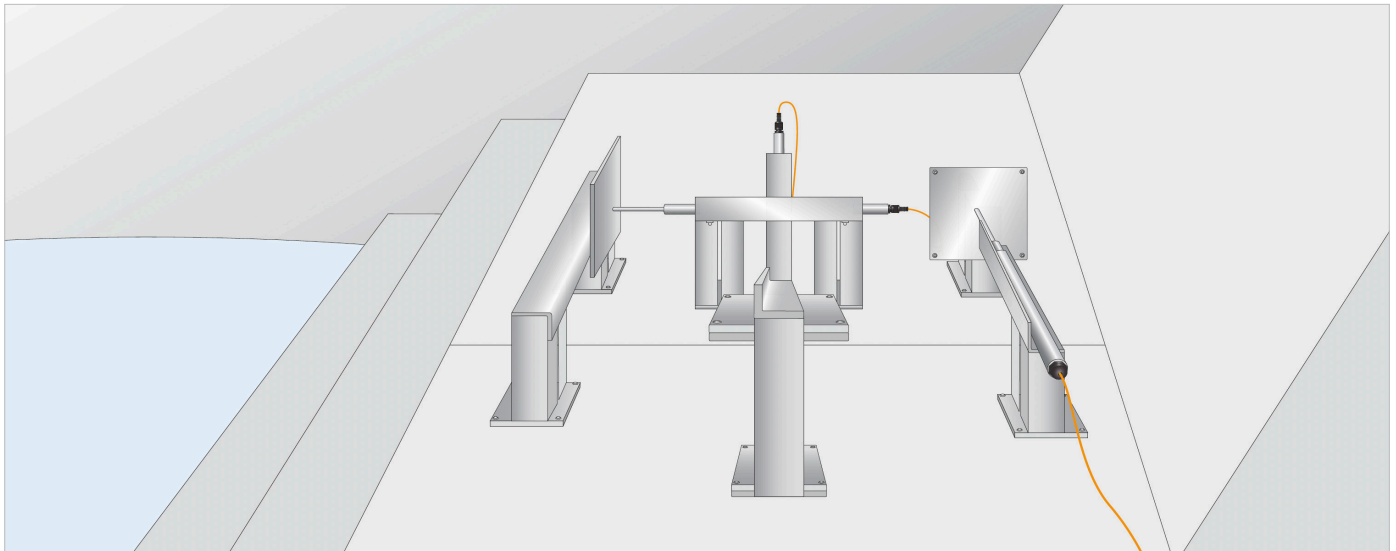

THE TECHNICAL RATING FOR THIS PRODUCT:

BASIC 

As the correct installation of any monitoring sensor or system is vital to maximise performance and accuracy, Soil Instruments makes the following recommendations, for the skill level of the installation contractor.

ADDITIONAL SUPPORT

We offer installation and monitoring services to support this system. For more information please email : sales@soilinstruments.com or call : **+44 (0) 1825 765044**

ADVANCED 

The installer is trained and experienced in the installation of this type of instrument or systems, and is ideally a specialist Instrumentation and Monitoring contractor.

INTERMEDIATE 

The installer already has previous experience and/or training in the installation of this instrument or system.

BASIC 

As a minimum the installer has read and fully comprehends the manual, and if possible has observed these instruments or systems being installed by others.

Specifications

Vibrating Wire Transducer

Range	50mm	100mm
Resolution ¹	0.025% full scale	
Accuracy	±0.2mm% full scale	
Temperature range	-20 to +80°C	
Weight less cable	190g	254g
Dimensions ²	L 290mm x Ø19mm	L 450mm x Ø19mm
Excitation method	Pluck or sweep	
Material	316 grade Stainless Steel	
Ingress protection	IP68 to 1500kPa	

Cable

Construction	4 Core, PUR sheath, foil screen & drain wire
Diameter	4mm
Weight/m	30g

Thermistor

Type	NTC 3k Ω
Accuracy	±0.5°C
Resolution ¹	0.1°C

¹ Dependent on readout

² Fully extended

Ordering Information

Vibrating Wire Triaxial Perimetric Jointmeters

Includes 3No. VW displacement transducers, mounted on arms with anchors, thermistor and over voltage arrestor - sealed to 15Bar.
Armoured cable can only be fitted on site with joint sealing kit CA-4.1

J4-1.1	Vibrating Wire Triaxial Perimetric Jointmeter; 50mm range
J4-1.1-C	Protective cover; for Triaxial Perimetric Jointmeter

Vibrating Wire Perimetric Jointmeters

Includes VW displacement transducer, mounted on arms with anchors, thermistor and over voltage arrestor - sealed to 15Bar.
Armoured cable can only be fitted on site with joint sealing kit CA-4.1

J4-2.1	Vibrating Wire Perimetric jointmeter; 50mm range, normal movement plane
J4-2.2	Vibrating Wire Perimetric jointmeter; 50mm range, shear movement plane
J4-2.3	Vibrating Wire Perimetric jointmeter; 50mm range, parallel movement plane
J4-2.4	Vibrating Wire Perimetric jointmeter; 100mm range, normal movement plane: to achieve full 100mm range the jointmeter should be submerged in water
J4-2.5	Vibrating Wire Perimetric jointmeter; 100mm range, shear movement plane: to achieve full 100mm range the jointmeter should be submerged in water
J4-2.6	Vibrating Wire Perimetric jointmeter; 100mm range, parallel movement plane: to achieve full 100mm range the jointmeter should be submerged in water
Protective covers for Perimetric Jointmeters are customised to the joint required. Should you require a protective cover please specify at time of order.	

Connecting Cable and Fittings

CA-3.1-4-IC	Instrument cable, 4 core, 7/0.20; screened, priced per metre, polyurethane jacket
CA-2.2-12-SC	12 core, multicore cable, 7/0.20; screened, priced per metre, PVC jacket
RO-JB-TJM	Junction box; for 3No. VW Displacement Transducers into 12 core multicore cable
CA-4.1	Joint sealing kit
CA-4.2	Coloured adhesive tapes; set of 10No.
CA-4.3	Crimping tool
CA-4.4	Crimping sleeves; set of 100No.
W6-6.1	Nylon ties; priced each, 150mm x 3.5mm, pack of 100No.
ST1-3.5	Nylon ties; priced each, 370mm x 4.7mm, pack of 100No.

Installation Equipment

W6-4.4	Polyester resin cartridge; 150ml, to fix anchor into drill hole
W6-4.5	Cartridge injection tool

Manual

MAN-115	Vibrating Wire Perimetric Jointmeter
---------	--------------------------------------

soil
INSTRUMENTS



Bell Lane, Uckfield, East Sussex
TN22 1QL United Kingdom

t: +44 (0) 1825 765044
w: soilinstruments.com

e: sales@soilinstruments.com