

Solid State 4-20ma Piezometer User Manual



Man194	2.1.0	07/08/2014	C. Rasmussen P. Day	P. Day	Chris Rasmussen
Manual No.	Revision	Date	Originator	Checked	Authorised for Issue

Contents

Section 1 : Foreword	3
Section 2 : Introduction	4
Section 3 : Effect of Temperature and Pressure	5
3.01 Temperature Change	5
3.02 Effect of Barometric Pressure (non vented transducers)	5
Section 4 : Preparation and Installation of Piezometer	6
4.01 Removal and Assembly of Filter Element	6
4.02 Pre-Installation Base Reading	6
4.03 Borehole Installation	6
4.04 Installation in Fill	7
Section 5 : Installation and Termination of Cable	8
5.01 Installation in Trenches	8
5.02 Cable Jointing	8
5.03 Preparation of the cable	8
5.04 Wiring & Power Supply for 4-20mA Loop	9
5.05 Fitting Mould	9
5.06 Filling with resin	9
5.07 Termination of cables	9
Section 6 : Calibration Details	11
Section 7 : Temperature	12
Section 8 : Troubleshooting	13
Figure 2: Preparation of Cable Joint	14
Figure 3: Cable Joining kit Wrapping Electrical Connectors and Mould Fitting.	14

Section 1 : Foreword

It is essential that the equipment covered by this manual is both installed and operated by competent and suitably qualified personnel. They must both **READ AND UNDERSTAND** the procedures outlined in this manual before attempting installation or operation of the equipment on site.

IT IS VITAL THAT THE PERSON(S) INSTALLING THESE PIEZOMETERS IS(ARE) FAMILIAR WITH THE TAKING OF PRE-INSTALLATION BASE READINGS.

All systems are designed to operate consistently under normal field conditions, and although their components are relatively robust, they will not survive mishandling or neglect. Treat all items with respect and handle with care.

These techniques serve as a general guide and will require modification to suit particular circumstances on site.

Section 2 : Introduction

The Solid State Piezometer comprises a porous element with an integral diaphragm type solid state pressure transducer. The transducer body is constructed throughout from stainless steel and comprises a rigid cylindrical body, sealed at one end by a firm bulkhead and at the other by a thin diaphragm which serves as a force sensing member.

The cylindrical body, diaphragm and sensing element with surge protector form a totally sealed independent unit. The electrical surge protector is included in the design to prevent damage should excessive voltages be induced into the connecting cable during electrical storms.

The piezometer works on the well-established 4-20mA current loop principle and can be read by any commercial 4-20mA readout.

Section 3 : Effect of Temperature and Pressure

3.01 Temperature Change

The materials used in the construction of the transducer are carefully chosen and controlled in order to reduce the effect of ambient temperature changes on readings. The significance of temperature change is always with respect to the temperature difference between the current time and the time of the pre-installation base reading. The temperature affect is most significant where thin diaphragms are fitted ie. the low range transducers (100, 200, 350 kPa). As a 'rule of thumb', considering the accuracy of the transducer as $\pm 0.1\%$ F.S. and the temperature affect to be $\pm 0.025\%/^{\circ}\text{C}$ F.S, installed temperature changes of less than 10°C are not, for practical purposes, significant.

If large temperature changes are to be expected in the ground where the piezometers are to be installed then consideration must be given to specifying the incorporation of a thermistor in each transducer or the separate installation of another temperature measuring device - in order to provide the temperature data required if corrections are to be applied. For details of how temperature correction coefficients applied, please refer to Troubleshooting in Section 8.

Temperature gradients across the transducer, triggered by rapid changes in ambient temperature, will produce considerable reading error. For this reason it is essential that pre-installation base readings are only taken after sufficient time has been allowed for the transducer to stabilise at the ambient temperature. Piezometers must be immersed in shallow water and shaded from direct sunlight until readings have been seen to settle.

3.02 Effect of Barometric Pressure (non vented transducers)

External pressure applied to the diaphragm of the transducer modifies the output. Such a change is used to determine the magnitude of the applied pressure. However, since the unit is evacuated and sealed during manufacture subsequent external variations in barometric pressure will cause a differential force to act across the diaphragm which will affect the output proportionally. Again the effect is most significant with thin diaphragms i.e. low transducers. For a 100kPa transducer a ± 10 millibar change in ambient barometric pressure (equivalent to 100mm of water head) relative to the encased pressure within the transducer will modify the reading by the equivalent of $\pm 100\text{mm}$ of water head, even though the external water head to be measured remains constant. Thus in applications where such relatively small variations are considered to be significant, correction of reading errors due to barometric pressure changes should be applied, (for this purpose a note of barometric pressure on the day of the pre-installation base reading is required and also an accurate barometer must be available on site).

Section 4 : Preparation and Installation of Piezometer

4.01 Removal and Assembly of Filter Element

For stainless steel elements with the piezometer placed in clean water remove the filter assembly. Invert the piezometer and the filters so no air remains in either, reassemble the filter. Ensure the piezometer is fully immersed throughout this operation and stays so until immediately prior to installation

4.02 Pre-Installation Base Reading

It is necessary to establish a base reading for each instrument prior to installation.

Prior to proceeding with the procedure below, the operator should be familiar with the use of the Readout/Logger chosen.

4.4.1 Ensure that the piezometer is totally immersed in water to the depth of a few centimetres only and is shielded from direct sunlight.

4.4.2 Connect the instrument cable to the Readout/Logger and record reading mA

4.4.3 Wait 15 minutes and repeat reading operation. A value identical to that obtained in 4.4.2 above indicates that the transducer has stabilised to the water temperature. Record reading with the prevailing barometric pressure and water temperature. Should results obtained at 4.4.2 and 4.4.3 be at variance, continue reading until stability is noted. Record with the prevailing barometric pressure and water temperature.

4.03 Borehole Installation

Before commencing with the installation, the following parameters should be established;

- 1) Depth of instrument.
- 2) Diameter of borehole.
- 3) Length of response zone.
- 4) Length of bentonite seal.
- 5) Type of backfill material.
- 6) Type of instrument termination.

The sides of the borehole in the vicinity of the piezometer tip should be free from slurry mud cake and debris. If the hole requires casing, this is withdrawn to keep pace with the installing operation. On completion of the borehole, consideration should be given to flushing it with clean water especially if fine silt is likely to enter the borehole. Before installation the borehole shall be clear of all sediment and drilling detritus. A head of water will ease installation of the piezometer but obviously this is not appropriate in highly impermeable soils. If the borehole is completely dry add a little water to cover the instrument during installation.

4.5.1 Place coarse clean filter sand through the water (a tremie pipe is useful for this) and allow time for it to settle prior to compacting to the proposed base of the piezometer tip. In silty or granular materials it may be necessary to maintain a positive head of water to prevent ingress of the parent material through the base of the borehole.

4.5.2 Mark the proposed depth of the tip on the piezometer cable using coloured P.V.C. adhesive tape. Remember to take account of any borehole casing remaining above ground level. Just

prior to installation measure the water level in the borehole. Carefully lower the piezometer down the borehole until the tape mark coincides with ground level.

- 4.5.3 Take a reading on the piezometer, allowing time for temperature equilibrium to be established (see 5.2 above). The calculated head of water should agree with the measured water level
- 4.5.4 Place further filter sand around the tip until the filter zone is the specified length. Remember to allow time for the sand to settle as it is impossible to remove surplus sand without causing considerable disturbance.
- 4.5.5 Usually a seal of bentonite pellets is placed above the sand filter to prevent entry of grout. Balls of stiff bentonite not larger than 50mm in diameter, can be used as an alternative to bentonite pellets. If casing is installed it should be withdrawn in conjunction with the placing of the sand and bentonite.
- 4.5.6 Backfilling is completed to ground level or the next piezometric horizon with an impervious grout, generally a bentonite-cement mix placed through a tremie pipe positioned above the bentonite plug and withdrawn as grouting proceeds. Casing should be withdrawn in conjunction with the placing of the grout.
- 4.5.7 If more than one instrument is being installed, it is important to clearly identify the cables using colour coded P.V.C. adhesive tapes.

4.04 Installation in Fill

- 4.6.1 Installation in Clay Fill: Excavate a small pocket in the fill material at the required location. Usually this is done at the base of the cable trench that will lead the cable to the instrument terminal unit. Place the piezometer upright in the hole and backfill around it with parent material. Compact the fill to the same density in the surrounding fill. Loop the cable above the piezometer and lead it back to the terminal unit. Backfill the cable trench as per the Contract Specification.
- 4.6.2 Installation in Rockfill: In rockfill or coarse granular material it is necessary to form a pocket of coarse clean sand around the tip to prevent damage to the filter element. Each particular site situation should be individually considered in these terms but with the common denominator that effective protection of the buried piezometer is essential.

To prevent the sand migrating into the surrounding rockfill it may be necessary to upgrade the pocket from sand at the centre to coarse gravel size or greater on the periphery. An alternative is to surround the sand with a geotextile wrap.

Section 5 : Installation and Termination of Cable

Connecting cable is laid in a trench deep enough to provide protection from mechanical damage. In certain situations the cables may be run in protective conduits or cast into concrete. However, great care should be taken to protect cables at interfaces between such relatively rigid conduits and flexible soil areas should this method be favoured.

The choice of suitable protection material surrounding the cable along the trench length will depend on local factors, but in all cases should be fine grained with a particle size less than 0.5mm and not contain any sharp particles. Fine sand is favoured in free draining areas, but should be replaced by screened silt or clay based soil where lower permeabilities are required. Failure to do so could result in piping along the trenchlines.

5.01 Installation in Trenches

When cables are to be laid in a trench they should be protected with 150mm of compact stone-free material normally sand, silt or clay around their longitudinal axis. Although sand is often most convenient to use, only silty clay or clay should be used where the creation of a drainage path is undesirable. Where the trench passes through the impervious clay core of an embankment dam additional bentonite cut-off points across the trench are necessary. If the trench is to be backfilled using rockfill or coarse granular material the thickness of the protective layer over the cables should be increased to 250mm.

The cables are laid loosely in the trench, snaked to prevent strain due to ground movements; in most cases a wavelength of 3m and an amplitude of 200mm should be sufficient. In certain cases it may be advisable to separate the cables from each other in the base of the trench. Cables are looped on crossing an interface where differential ground movements might be anticipated. Cables must also be looped at cable joints. Cables should be identified using coloured P.V.C. tape applied at regular intervals.

The correct functioning of the instrument is checked before backfilling the trench. Compaction of backfill is carried out using only hand operated equipment. It may be advisable to clearly mark out or survey the position of the instrument trench, particularly if there is to be further excavation or borehole drilling in the vicinity. A record of the trench position and depth should be kept.

5.02 Cable Jointing

It is desirable to minimise cable joints, but where they are unavoidable, a special joint kit may be supplied. The effectiveness of this joint largely depends on the care with which the jointing operation is carried out.

Please refer to figures 2 and 3 at the end of this manual.

5.03 Preparation of the cable

Thoroughly scrape all wax and dirt from each cable end for approx. 150mm. Prepare the cable ends as shown. Stagger the individual connections.

5.04 Wiring & Power Supply for 4-20mA Loop

A 2-core cable connects to the piezometer, this must be wired and powered as per the table below:-

Conductor Colour	Identification
Red	Power+ (12-18VDC)
Blue/Black	Ground

For best results, solder all connections, if this is unavailable on site; use the crimped connectors to join the conductors. Ensure electrical continuity of outer armoured screen is re-established across the joint and that the piezometer is reading as expected. Use the electrical insulation tape to wrap the connectors and apply one layer half lapped over connector area only.

5.05 Fitting Mould

Trim the ends of the mould with a sharp knife to suit the diameter of the cable. Hold the mould halves in place centred over the splice. Snap both halves together and fit the pouring spouts in the holes. Ensure that both seams are completely snapped together. Tape the ends of the mould body to form a seal.

5.06 Filling with resin

Mix the resin thoroughly and maintaining the mould in a level position, spouts uppermost, pour the resin through one spout until both spouts are completely filled. When the resin has solidified and cooled remove the spouts.

NOTE: In cold weather (below 15° C) the resin becomes very viscous. It is therefore advisable to keep the resin in a warm place prior to mixing. Mix the compound until its temperature starts to rise, this decreases the viscosity.

5.07 Termination of cables

The cables are normally terminated in a 12, 24 or 48 channel terminal unit or directly to an Automatic Datalogger specially commissioned for the project. The cables enter through waterproof glands. The terminal units have a hinged lid, which is secured with 4no. or 6no. screws depending on its size.

The cables are terminated as follows:-

5.7.1 Unscrew the cover and carefully remove the fascia plate without straining the interconnecting ribbon cables disconnect the Insulation Displacement Connector (IDC) whilst holding the fascia panel. Put fascia in a safe place whilst proceeding to terminate the piezometer cables.

- 5.7.2 Prepare the cables by stripping and cutting back 75-100mm approx. of the outer insulation and by teasing out the armour/screen maintaining a sufficient number of conductors from the armour/screen for making earth connections and cut back the surplus. Remove the rubber packing and strip back 5mm of the conductor insulation.
- 5.7.3 Slacken the entry glands and insert the cables. Make connections to the contact block (details of colour coding supplied with each instrument.) Retighten the glands to grip the cables.
- 5.7.4 Replace the terminal panel and secure. Connect the readout to each instrument in turn to check connections.

Section 6 : Calibration Details

The sensor is calibrated as mA output –Vs- pressure in units of Bar. A sample calibration certificate is overleaf. From the calibration a slope and intercept factor are determined, which can be clearly seen on the calibration certificate.

Also on the certificate are calculated pressure (using the slope and intercept values) and a %FS error for each calibration division.

Alternative calibration certificates in different units of pressure (e.g. kPa) are available if required from Soil Instruments (there is a cost for this service).

Example Calibration Sheet



Bell Lane, Uckfield, East Sussex
 TN22 1QL United Kingdom t: +44 (0) 1825 765044 e: info@soilinstruments.com w: www.soilinstruments.com
 Soil Instruments Limited. Registered in England. Number: 07960087. Registered Office: 3rd Floor, 1 Ashley Road, Altrincham, Cheshire, WA14 2DT, UK

4-20mA INSTRUMENT CALIBRATION CERTIFICATE

Instrument Type	: 350 kPa Absolute sensor 4 - 20mA O/P	Serial No.	: SSP416
Instrument Range	: 0kPa to 350kPa	Calibration Date	: 13/06/2017
Gauge Factors in kPa		Ambient Temperature	: 22 °C
Linear Gauge Factor (G)	: 21.5703269	Barometric Pressure	: 1017 mbar
Linear Intercept (I)	: -82.5104849	Calibration Technician	: M Bratton
Polynomial Gauge Factor A	: 0.007302666081078	Calibration Equipment	
Polynomial Gauge Factor B	: 21.3961177532	Traceable to National Standards :	
Polynomial Gauge Factor C**	: -81.663787	Mensor APC 600	
Regression Zero	: 3.83	Calibrated Multimeter Serial No: 1749	

Absolute Pressure (kPa)	Reading (mA)	Calculated Pressure (Linear)	Error %FS (Linear)	Linear Increment (mA)	Calculated Pressure (Polynomial)	Error %FS (Polynomial)
0.00	3.821	-0.09	-0.03		0.20	0.06
35.00	5.442	34.88	-0.04	1.621	34.99	0.00
70.00	7.060	69.78	-0.06	1.618	69.76	-0.07
105.00	8.681	104.74	-0.07	1.621	104.63	-0.11
140.00	10.335	140.42	0.12	1.654	140.25	0.07
175.00	11.960	175.47	0.13	1.625	175.28	0.08
210.00	13.566	210.11	0.03	1.606	209.94	-0.02
245.00	15.191	245.16	0.05	1.625	245.05	0.01
280.00	16.804	279.96	-0.01	1.613	279.94	-0.02
315.00	18.425	314.92	-0.02	1.621	315.04	0.01
350.00	20.035	349.65	-0.10	1.610	349.94	-0.02

Formulae: **Linear*** E = GR + I
Polynomial** E = AR₁² + BR₁ + C

*The zero reading must be established on site by the user prior to installation.

**The site value of C must be calculated using the formula C= -(AR₀² + BR₀)

The instrument detailed hereon has, as applicable, been tested and calibrated in accordance with procedures, which are part of our ISO9001:2008 Quality Management System and unless otherwise indicated, performs within +/-0.10% as specified. Thus, the instrument conforms in all respects to our relevant specifications and drawings.

Certified: Line MANAGER

Section 7 : Temperature

The Solid State Piezometer is designed to be used within the temperature range of 1 - 30°C. Within this range there is a minimal temperature effect (below the resolution of the instrument). Above 30°C a temperature calibration will be required to meet the published specification of the instrument. As a guide, up to 30°C the shift (both span and offset) of the piezometer due to δt is in the order of 0.025%FS°C

Should the above figure be beyond acceptable limits for the installation, do not install the piezometer and contact Soil Instruments for advice.

Section 8 : Troubleshooting

If a failure of any transducer or the electrical cable is suspected, the following steps can be followed. The transducers themselves are sealed and cannot be opened for inspection. The "Troubleshooting Flowchart" should also be followed if any instrument failures are suspected.

The steps below and the Troubleshooting Flowchart are applicable generally to any vibrating wire instrument.

STEP 1

Before any of the following steps are followed, a portable readout should be used to verify the stability of the reading. An unstable (wildly fluctuating) reading from a transducer indicates possible problems with instruments or their related electrical cables.

If a portable readout is giving faulty readings from all transducers, a faulty readout unit must be suspected. Another readout unit should be used to check the readings from the transducers.

STEP 2

The resistance across the two conductors of the electrical cable should be checked. This can be done using a multimeter device across the two exposed conductors if the cable has not been connected to a terminal cabinet, or can be done just as easily across the two conductors if the instrument has been connected to such a terminal (or Data Logger).

The resistance across the two conductors should be approximately of the order of $5\text{m}\Omega$ or higher. (Note, do not touch the bare probes of the Ohmmeter whilst making this measurement, or a false reading will be displayed).

Before proceeding to Steps 3 and 4, the continuity should be checked between conductors and earthing screen of the electrical cable. If continuity exists, a damaged cable is confirmed.

STEP 3

If the resistance across the two conductors is much higher than the values quoted in "STEP 1" (or is infinite), a severed cable must be suspected.

STEP 4

If the resistance across the two conductors is much lower than the values quoted in "STEP 1" (say $100\text{k}\Omega$ or less) it is likely that cable damage has occurred causing a short in the circuit.

STEP 5

If the resistance is within the values quoted in "STEP 1" AND no continuity exists between conductor and earth screen and on checking the reading from the transducer, it proves to be still unstable or wildly fluctuating, it must be assumed that the integrity of the circuit is good. A faulty transducer could be suspected if neighbouring construction activities do not account for the anomaly Soil Instruments should be consulted.

If the point at which the cable is damaged is found, the cable can then be spliced in accordance with recommended procedure

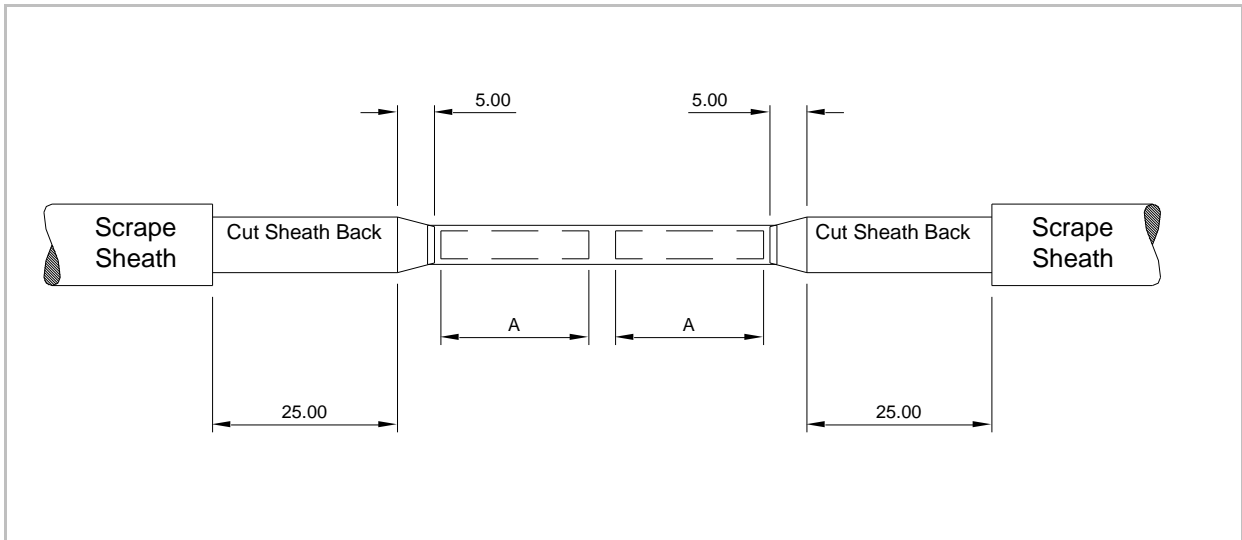

Figure 2: Preparation of Cable Joint

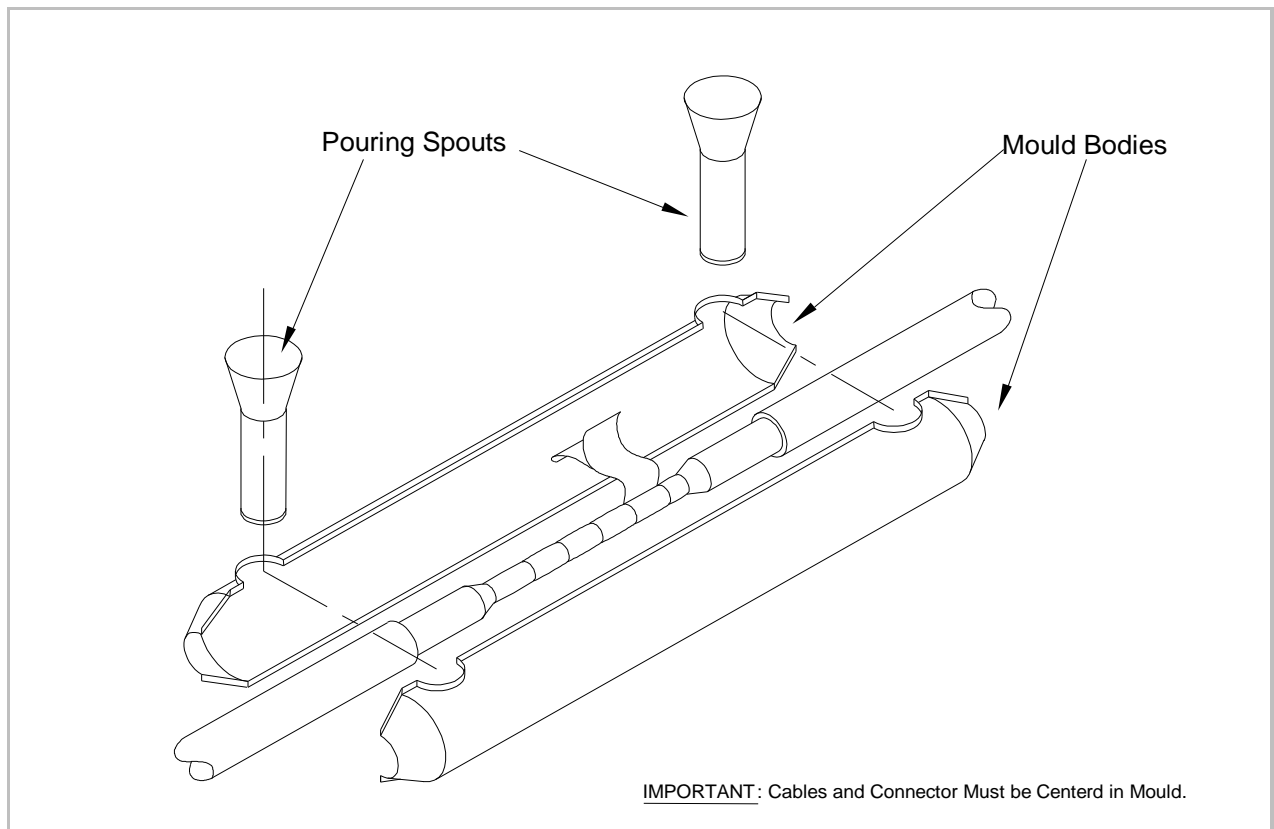

Figure 3: Cable Joining kit Wrapping Electrical Connectors and Mould Fitting.



Bell Lane, Uckfield, East Sussex

TN22 1QL, United Kingdom

t: +44 (0) 1825 765044

e: info@soilinstruments.com

w: www.soilinstruments.com

Soil Instruments Ltd. Registered in England. Number: 07960087. Registered Office: 3rd Floor, Ashley Road, Altrincham, Cheshire, WA14 2DT