

Strain Gauge Load Cell
User Manual



Man211	2.1.0	06/08/2014	Philip Day	Philip Day	Philip Day
Manual No.	Revision	Date	Originator	Checked	Authorised for Issue

Contents

Section 1 : Forward	3
Section 2 : Introduction	4
2.01 Equipment Supplied & Wiring	4
Section 3 : Preparation	6
Section 4 : Installation	7
4.01 Installation of Load Cells for Rock Bolts and Cable Anchors	7
4.02 Installation of Load Cells for Struts and Columns	7
Section 5 : Data Interpretation & Calibration Certificate	9

Section 1 : Forward

This instruction manual, describes the technique required for the installation of centre hole load cells.

It is important that the materials and equipment covered by this manual should be installed by competent and suitably qualified personnel. They must READ AND UNDERSTAND the procedures outlined in this manual before attempting installation of the equipment on site.

Soil Instruments will not accept for repair under guarantee, instruments/materials neglected or mishandled in any way.

The techniques described are intended to serve as a general guide and may vary to suit particular site conditions.



Section 2 : Introduction

The Strain Gauge Load Cell has been designed for the measurement of loads in rock bolts, single/multi-stranded anchors, structural beams, piles and between tunnel lining segments.

The Load cell Incorporates up to 16 resistance strain gauges in a Wheatstone bridge configuration. The Gauges are equally spaced within a cell manufactured from a high quality stainless steel, precisely machined to provide a stable load-bearing ring.

The Load cell is supplied as either an mV/V output or as a 4-20mA 2 wire loop.

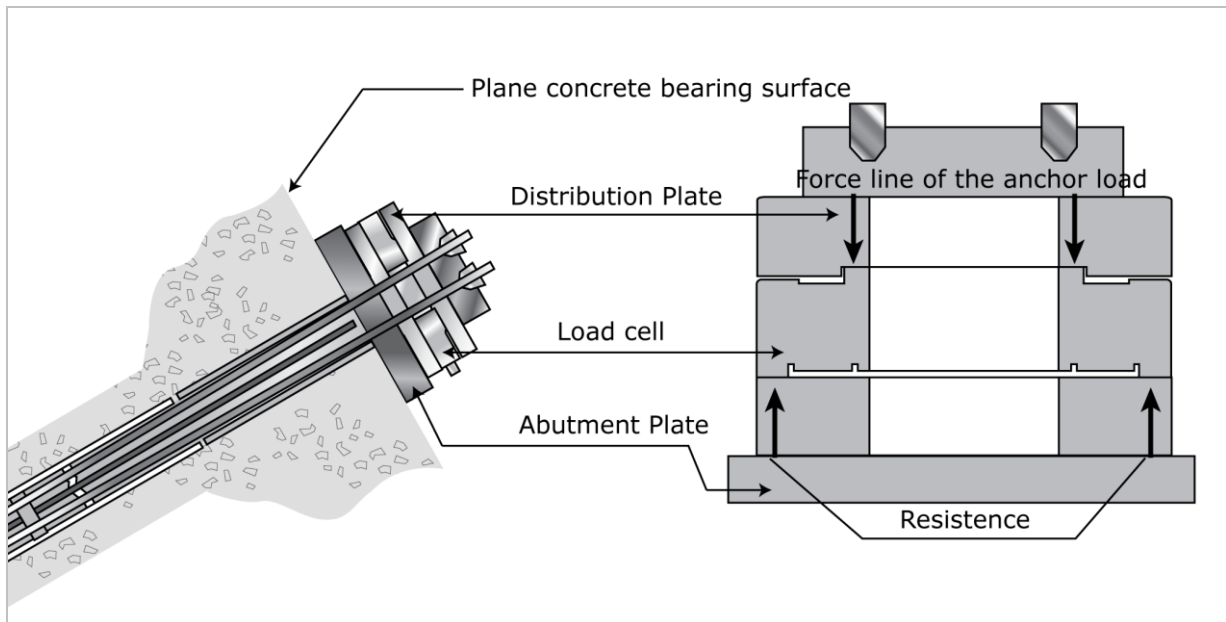

2.01 Equipment Supplied & Wiring

Each Load cell is supplied with heavy gauge multicore, PVC sheathed cable to the length specified by the user at time of ordering.

Although the Load cells are checked prior to leaving Soil Instruments, damage could occur during transit. It is suggested that the load cells are visually checked immediately upon receipt. Additionally it is prudent to check the operation using a readout device.

The cable cores are identified as follows:

4-20mA Loop Output	mV/V Output	Wire Colour
Loop +	Supply +	Red
Loop -	Supply -	Black
	Signal +	Green
	Signal -	White
	Ref +	Blue
	Ref -	Brown

The supply Voltage for mV/V output Load cell can be from 2 to 15 Volts DC and the 4-20mA output Load cell should have a supply voltage of 12 Volts DC.

The Ref+ and Ref- are used to monitor the supply voltage at the Load cell to ensure correct reduction of data into engineering units.

Soil Instruments recommends the use of its specially designed distribution plates to ensure correct measurements from the Load cell are achieved.

Distribution plates should not be a smaller thickness than the Load cell and should not have internal diameters smaller than that of the Load cell.

The abutment plate should be at least 20mm larger in diameter and not be smaller in thickness than that of the Load cell or be mounted on a tube with dimensions which do not fall within the internal and external diameters of the Load cell.

Section 3 : Preparation

Warning: Do not hit or strike the cell at any time with a hammer or other object. A reading **MUST** be established on the unloaded cell prior to installation and after loading has taken place.

Where a number of Load cells are to be installed it is essential that each Load cell and its associated cable are accurately and effectively identified. A permanent marking system should be adopted to ensure Load cells can be identified throughout their working lifetime and this information safely stored for future reference.

It is essential that the load bearing surfaces above and below the Load cells are smooth and flat, parallel and sufficiently strong to avoid significant distortion under load. Positioning and alignment of the cells is critical to their performance.

The surface to which the Load cell is to be installed should be flat and perpendicular to the anchor. If a steel abutment plate is provided on the structure face it should ideally be beaded onto resin or cement to ensure complete contact between the structure and the abutment plate with no voids beneath the plate. The area to be covered by the Load cell assembly should be cleaned. In particular remove any paint and smooth out score marks and rough imperfections with a file and abrasive paper.

Check that all the items for the installation are readily available i.e. Load cell, top and bottom distribution plates, readout unit, calibration data for Load cell, anchor stressing equipment and where necessary lifting equipment to support the weight of the Load cell.

The Load cell serial number and installation location should be checked and recorded.

Prior to installation, the cell should be stored close to its installation location to enable the instrument to come into equilibrium with its temperature environment.

Section 4 : Installation

4.01 Installation of Load Cells for Rock Bolts and Cable Anchors

- 4.0.1.1 Connect the readout unit to the Load cell and record the base (unloaded) reading.
- 4.0.1.2 Carefully locate the bottom bearing plate, Load cell and top loading plate over the anchor, followed by the anchor plate and stressing nut (for single strand anchors) or anchor disc and collets (for multistrand anchors). Where centralising recesses or buttons are provided on the plates, ensure that these are correctly located. Suitable lifting tackle may be necessary in some installations to support the weight of the Load cell, plates and stressing equipment and to ensure correct alignment is maintained.
- 4.0.1.3 With the stressing equipment connected, slowly operate the hydraulic jack to provide sufficient load to lightly hold the Load cell assembly against the abutment plate. Check for alignment and concentricity of all the components to ensure that the anchor load is applied in line with the axis of the load cell.
- 4.0.1.4 At this stage the Load cell should be read and the reading converted to Engineering Units.
- 4.0.1.5 Loading of the anchor should be applied as per the values specified by the Engineer. Readings should be taken at each load increments if required and recorded.
- 4.0.1.6 Prior to locking off the anchor at the required working load a number of loading cycles should be carried out to at least the working load to check the performance of the Load cell and ensure that the anchor and Load cell are correctly bedded in.
- 4.0.1.7 Most installations require the anchor to be tested to a maximum of 1.5 times the eventual working load. The requirement for this operation should be checked and agreed with the Engineer before the final locking off of the anchor.
- 4.0.1.8 On completion of the installation the Load cell and bearing plates should be heavily greased on all exposed surfaces.
- 4.0.1.9 The protective cover must be adequate to protect the Load cell from damage as well as differential temperature changes. Reflective external surfaces and internal insulation will help eliminate this effect.

4.02 Installation of Load Cells for Struts and Columns

- 4.0.2.1 Connect the readout unit to the Load cell and record the base (unloaded) reading.
- 4.0.2.2 It is recommended that bearing plates are installed between the structural members/reaction and the Load Cell. They will need to be positioned carefully and where necessary fixed in place or supported. Suitable lifting tackle may

be necessary in some installations to support the weight of the Load cell and plates to ensure correct alignment is maintained.

- 4.0.2.3 With the Load Cell positioned where any Axial load will be transferred, slowly move the structural member into place and generate some pre-load. (This may be only the weight of the column or produced by applying a load via a hydraulic jack).
- 4.0.2.4 At this stage the Load cell should be read and the reading converted to Engineering Units.
- 4.0.2.5 Loading of the Load cell should be applied as per the values specified by the Engineer. Readings should be taken at each load increments if required and recorded.
- 4.0.2.6 Where possible a number of loading cycles should be carried out to at least the working load to check the performance of the Load cell and ensure that the load cell and bearing plates are correctly bedded in.
- 4.0.2.7 On completion of the installation the Load cell and bearing plates should be heavily greased on all exposed surfaces.
- 4.0.2.8 A protective cover adequate to protect the Load cell from damage as well as high differential temperature changes should be fitted to the installation. Reflective external surfaces and internal insulation will help eliminate this effect.

Section 5 : Data Interpretation & Calibration Certificate

As with any monitoring system it is essential that all the factors that could possibly affect the readings are recorded and taken into account such as atmospheric conditions and construction activities.

The calibration certificate supplied with the Load cells is calculated with the calibration information taken in units of mV/V or mA depending on the type of Load cell supplied.

The Load cell calibration certificate states a Slope (S) and Intercept (I) Value for the load cell which are used to convert the Load cell readings into engineering values (kN)

MV/V Calibration

Readouts and data loggers where the output is in mV

$$\text{Load (kN)} = \mathbf{I + ((S * R) / F)}$$

Where: S = Slope Factor from calibration certificate
 R = The current reading in mV
 I = The Intercept Factor from the calibration certificate
 F = The current reference reading in Volts

MV/V Calibration

Readouts and data loggers where the output is in mV/V

$$\text{Load (kN)} = \mathbf{I + (S * R)}$$

Where: S = Slope Factor from calibration certificate
 R = The current reading in mV/V
 I = The Intercept Factor from the calibration certificate

4 - 20mA Calibration

$$\text{Load (kN)} = \mathbf{I + (S * R)}$$

Where: S = Slope Factor from calibration certificate
 R = The current reading in mA
 I = The Intercept Factor from the calibration certificate

Calibration Certificate

Sensor Type : **Strain Gauge Load Cell** Date : **19 December 2016**
Instrument No : **CRR75-500** Ambient Temp : **20.0 °C**
Calibrated By : **S.HILL** Serial No : **201613683**

Calibration Equipment

Reference Multimeter Equipment No 1749 traceable to national standards
Signal Multimeter Equipment No 5155 traceable to national standards
Contest Press Serial No 5312 traceable to national standards

Calibrated Data

Applied Load (kN)	Readings (mV/V)	Best Straight Line (kN)	Deviation of full scale (%)
0	0.0039	-0.3776	-0.08
50	0.2012	49.7293	-0.05
100	0.4007	100.4060	0.08
150	0.5952	149.8167	-0.04
200	0.7938	200.2613	0.05
250	0.9923	250.6847	0.14
300	1.1867	300.0744	0.01
350	1.3836	350.0759	0.02
400	1.5781	399.4866	-0.10
450	1.7761	449.7835	-0.04
500	1.9740	500.0593	0.01

Load = (mV/V x S) + I	S = 254.01603 I = -1.36923
-----------------------	-------------------------------

Wiring Details

RED = + Supply
BLACK = - Supply
GREEN = + Signal
WHITE = - Signal
BLUE = + Ref
BROWN = - Ref

Supply Volts 2-15 Vcc

The instrument detailed hereon has, as applicable, been tested and calibrated in accordance with procedures, which are part of our ISO9001:2008 Quality Management System, and unless otherwise indicated, performs within +/- 0.50% as specified. Thus, the instrument conforms in all respects to our relevant specifications and drawings.

CertifiedLine Manager



Bell Lane, Uckfield, East Sussex

TN22 1QL, United Kingdom

t: +44 (0) 1825 765044

e: info@soilinstruments.com

w: www.soilinstruments.com

Soil Instruments Ltd. Registered in England. Number: 07960087. Registered Office: 3rd Floor, Ashley Road, Altrincham, Cheshire, WA14 2DT